

MODEL AA SERIES, AAP ASSEMBLY INSTRUCTIONS
YAMAHA MOTORS 115 HP V4 2 STROKE (AA4), 150-220 HP V6 2 STROKE (AA6)
115 HP I4 4 STROKE (AA115-4)

1. Place the engine on the transom of your boat so that it is mounted vertically, in the normal fashion. Remove the bolts holding the gearbox to the exhaust housing and remove the gearbox assembly.
2. Remove the water pump assembly from the propeller drive, including the lower stainless steel plate, dowel pins, and impeller drive key.
3. Install the jet driveshaft assembly into the spiral pump housing locking it in place with the four 5/16-18 x 1 bolts with lock washers. Use grease on the threads. Tighten to 15 Ft-Lbs.
4. Install the water pump assembly on top of the 3/4" thick aluminum adapter and stainless steel plate. No gaskets are used over or under the aluminum adapter. Be sure also, to install the water pump impeller drive key removed from the propeller drive. Lock in place using four 5/16-18 x 2 1/2 bolts and lock washers. Grease the threads. Tighten to 10 Ft-Lbs. **The tapered thrust ring assembly above the water pump on the propeller drive is not used on the jet drive.**
5. The large 3/4" adapter plate is attached to the exhaust housing to hold the jet drive. A 1/4 x 2" plastic shift rod guide in the front of the plate guides the disconnected shift rod. Two 8 x 12MM dowels locate the plate, seven M10 x 34MM bolts with lock washers secure it. Grease the bolt threads and the end of the pin where it slides in the shift rod. Tighten to 22 Ft-Lbs.
6. Next, attach the jet drive to the motor. Two 3/16 x 1/2 dowel pins center the jet drive on the adapter plate. Four 3/8-16 bolts from below and one 3/8-16 x 1-1/2 bolt from above rear with lock washers are used. Select the lower bolt lengths to suit the different counter bore depths so that all bolts enter the adapter plate the same depth. The upper rear bolt is reached through the trim tab opening in the motor exhaust housing.

Grease the bolt threads, driveshaft spline generously, and rubber water tube pilot and guide the jet into place. Tighten to 22 Ft-Lbs.

7. Next, install the impeller. Grease the shaft threads, key and impeller bore. Place the plastic sleeve inside the impeller, hold the key in the nose of the impeller with your forefinger and slide onto the driveshaft. Install the seven shim washers, rubber washer and cup, and nut retainer on the shaft, and bring the nut up snug by hand.

Then, bump the heel of your hand against the wrench to bring the nut up tight. If the ears of the retainer do not line up with the flats on the nut, spin the nut off, turn the retainer over and tighten the nut again. In one of these two positions you will have alignment and can fold the ears up against the nut to retain it. The flat in the retainer is angled to the ears to allow this.

When, after use in sand and gravel, the blade clearance becomes more than about 1/32" between the impeller edge and the water intake liner, one or more of the shim washers can be transferred from the bottom stack to the top of the impeller, which moves the impeller down into the tapered casing to reduce the clearance.

Shims should not be used above the impeller on new installations where no wear has occurred unless the blade clearance exceeds 1/32 inch. Insufficient blade clearance will do more harm than good from any performance gains it might provide.

8. Place the intake casing in position with the lower end at the rear and tighten the six nuts. No lock washers are used. Grease the threads.
9. Attach the shift cable and cable anchor bracket to the jet drive.

CAUTION **If your motor is HPDI, 2 cables will be attached to the cable anchor bracket and roller cam, to provide neutral start protection.** The outer cable comes from the remote control box to operate the reverse gate. It does not enter the motor housing. The shorter inner cable enters the motor housing to operate the neutral start safety switch and is driven by the movement of the reverse gate. The neutral start switch prevents starting the motor in forward or reverse. See 10* below.

10. With the shift handle in forward and the reverse gate in forward, **with the cam roller at the end of the slot,** adjust the cable and/or cable anchor position to this condition. **Shift to reverse and back to forward. The roller should be at the end of the cam slot such that the gate cannot be forcibly rotated toward reverse. Pull on the gate by hand to verify this.**

If this forward lock condition is not met, readjust the cable positions.

- 10.* **Shift to neutral and adjust the cable end in the motor housing so that the neutral start switch is activated.** Check adjustment coming from both forward and reverse to compensate free play in cable linkage. **HPDI ONLY.**
11. **When converting to jet drive, your motor will have to be raised to height shown in diagram below, using a straight edge under the boat.** Test run the boat and then raise or lower the motor 5/16 inch at a time to obtain the best results.

The motor has three sets of upper mounting holes. You will use one set to begin with. Mark pencil lines on the boat transom through the other sets. Then if you wish to go up or down 5/16 inch, you can drill one alternate set of holes 5/16 inch up or down from the pencil marks. By alternating between these two sets of transom holes and the three sets of motor holes, the motor can be moved in 5/16 inch increments over almost one inch. The transom height should be about 26" measured vertically from the boat bottom.

If you raise it too much it will suck air and cavitate, either on start up or when banking on turns. When cavitating, the motor over speeds in spurts and shakes considerably in the motor mount. **This is not a normal condition and should be avoided by proper adjustment of motor height on each individual boat.** If you lower it too much you will have excessive drag, therefore mount the motor as high as possible without allowing cavitation

SETTING MOTOR HEIGHT

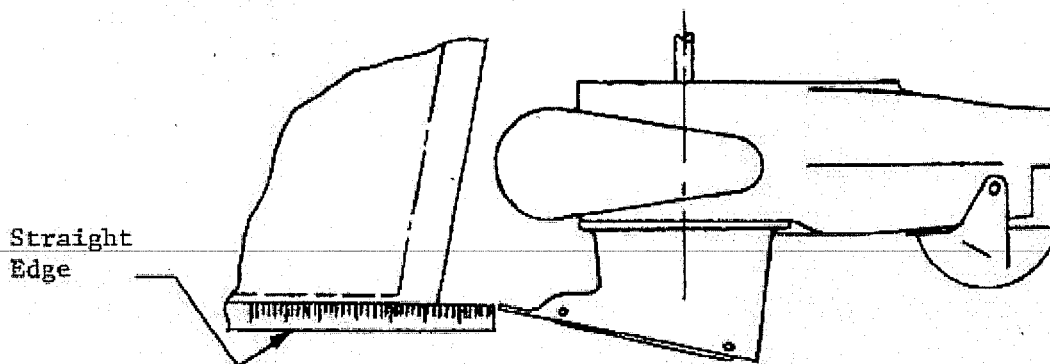

CAUTION

When starting the engine for the first time, watch to see that the cooling water comes out of the small hole at the rear side of the engine just below the power head. This is to check your assembly of the cooling water pump and its connections.

MAINTENANCE AND LUBRICATION

See last page.

CAUTION

V4 and V6 jet drives

It is important on high HP installations to mount the motor at the correct height and to use the power tilt properly.

Power tilt is convenient for drifting and when operating at low throttle in very shallow areas. When under power however, the engine should not be tilted out in an effort to gain speed as is done with propellers.

The engine driveshaft should be vertical when planing or tilted toward the boat in order to provide a scooping angle on the water intake grill. **Tilting the motor out beyond a vertical position reduces the scoop angle and can cause impeller slippage and cavitation burns on the impeller blades.**

When running in a bay, lake or wide river in windy conditions, particularly when running with the wind, the jet can suck in air when jumping across the wave crests. This will result in over speeding and causes severe strain on the driveshaft when the engine is suddenly brought back to normal speed as the impeller once again grabs solid water.

If your boat is used frequently under these conditions, the engine height should be set lower than normal to minimize over speeding. Running at reduced throttle will help when winds are strong. You can also experiment with a plate extending from the hull bottom to the top of the leading edge of the water intake as shown in paragraph 7 of the owners' manual. This tends to reduce air intake as well as to reduce spray.

A water intake fin kit, part #1186 (or #1726 for AAP) is now available. The purpose of these fins is to ram more water into the intake and to shield the forward sides of the intake from the entrance of air. There is a noticeable reduction of engine over speeding when running with the wind on a heavy chop. To a lesser degree, the fins provide some rudder effect when operating at a low speeds. This is not a cure all for cavitation and it is still necessary to set the engine height and angle properly and to minimize obstructions or imperfections in the hull ahead of the intake.

GOOD BOATING AND HAVE FUN!

Specialty Manufacturing Company
Outboard Jets
2035 Edison Avenue
San Leandro, CA 94577

MAINTENANCE AND LUBRICATION OUTBOARD JET DRIVE

BEARING LUBRICATION

A grease gun and tube of grease is supplied with your jet drive. We recommend greasing the bearing every 10 hours. Make greasing a part of your cleanup after the days use. Pump in just enough grease to fill the lube hose. Then reconnect the lube hose coupling to the zerk grease fitting.

Every 30-40 hours, pump in extra grease so as to purge any moisture. The texture of the grease coming out gives an indication of conditions inside the bearing housing. A gradual increase in moisture content indicates seal wear. If the grease begins to turn dark, dirty gray, the bearing and seals should be inspected and replaced if necessary. Some discoloration of the grease is normal during the break in period on new sets of seals.

We have selected a water resistant grease of the proper consistency for this application. If you use a substitute grease, be sure it is water resistant and of the same consistency.

IMPELLER

Your jet drive is equipped with a key to protect the unit in the event of a rock jam. This can be reached by removing the water intake, and then the driveshaft nut, similar to a propeller drive. After replacing the key, pull the shaft nut up tight to remove any play between the impeller and shaft. Note the position of the impeller shim washers, and replace them in the same order.

REVERSE GATE MECHANISM

Occasionally check adjustment of the gate shifting linkage. In "forward" the gate should be firmly locked in position. Pull on the gate by hand to verify this. This will prevent wave action from accidentally shifting the gate into reverse as the boat is violently maneuvered

GENERAL

Check all mounting bolts, intake screws, linkage connections, etc., occasionally to be sure they are tight.

SALT WATER USE

Aluminum and stainless steel have been used in the construction of your jet drive. These materials have either been treated or are inherently resistant to corrosion. It is recommended, however, that when not in use the motor be tipped up so that the jet unit is out of the water. When used in salt water more than in fresh water, remove mounting hardware, grease, and reassemble once a year. Failure to do this may result in hardware that is difficult if not impossible to remove at a later date.

GUARANTEE

Due to inflexible government regulation, we do not have a written warranty. We have, however, a good reputation for fairness with our customers which we intend to maintain. If you think you have a warranty situation, regarding material, workmanship, call us before making repairs.

Specialty Manufacturing Company
Outboard Jets
2035 Edison Avenue
San Leandro, CA 94577

LARGE SERIES

NEUTRAL CABLE ASSEMBLY
AA6P, HPDI, AQ, AJSM06-43
1566.3

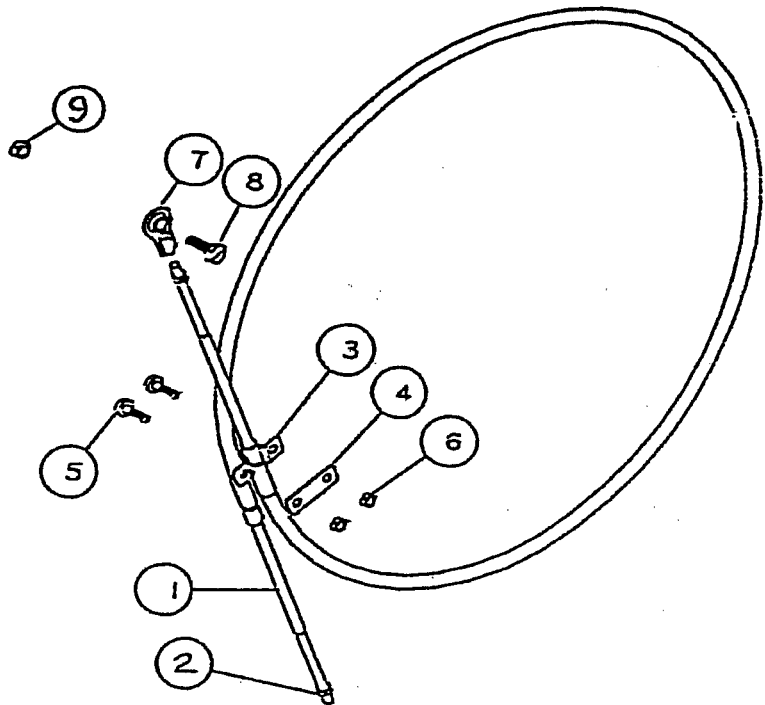

REF	QTY	PART NO.	DESCRIPTION
1	1	547.2	CABLE 5 FT MOR 33C SUPREME
2	2	621.1	HEX NUT 10-32 JAM
3	1	543	CLAMP CHRYS 154317
4	1	542	SHIM MORSE AO35777
5	2	561.1	SCREW #10-24 X 3/4
6	2	619	NYLOC #10-24
7	1	553.2	BALL END 1/4X10-32 CABLE
8	1	585	BOLT HEX HD 1/4-20 X 1 1/4
9	1	623	NYLOC 1/4-20

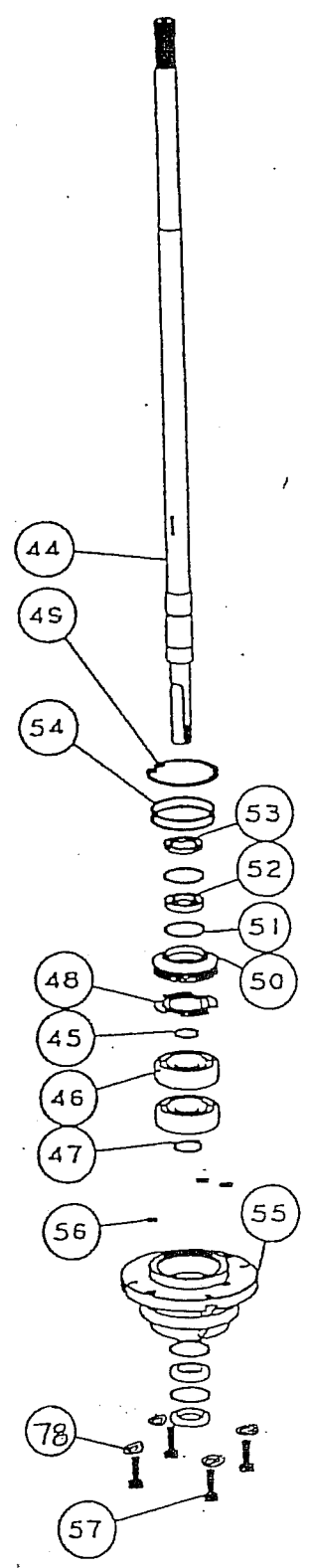
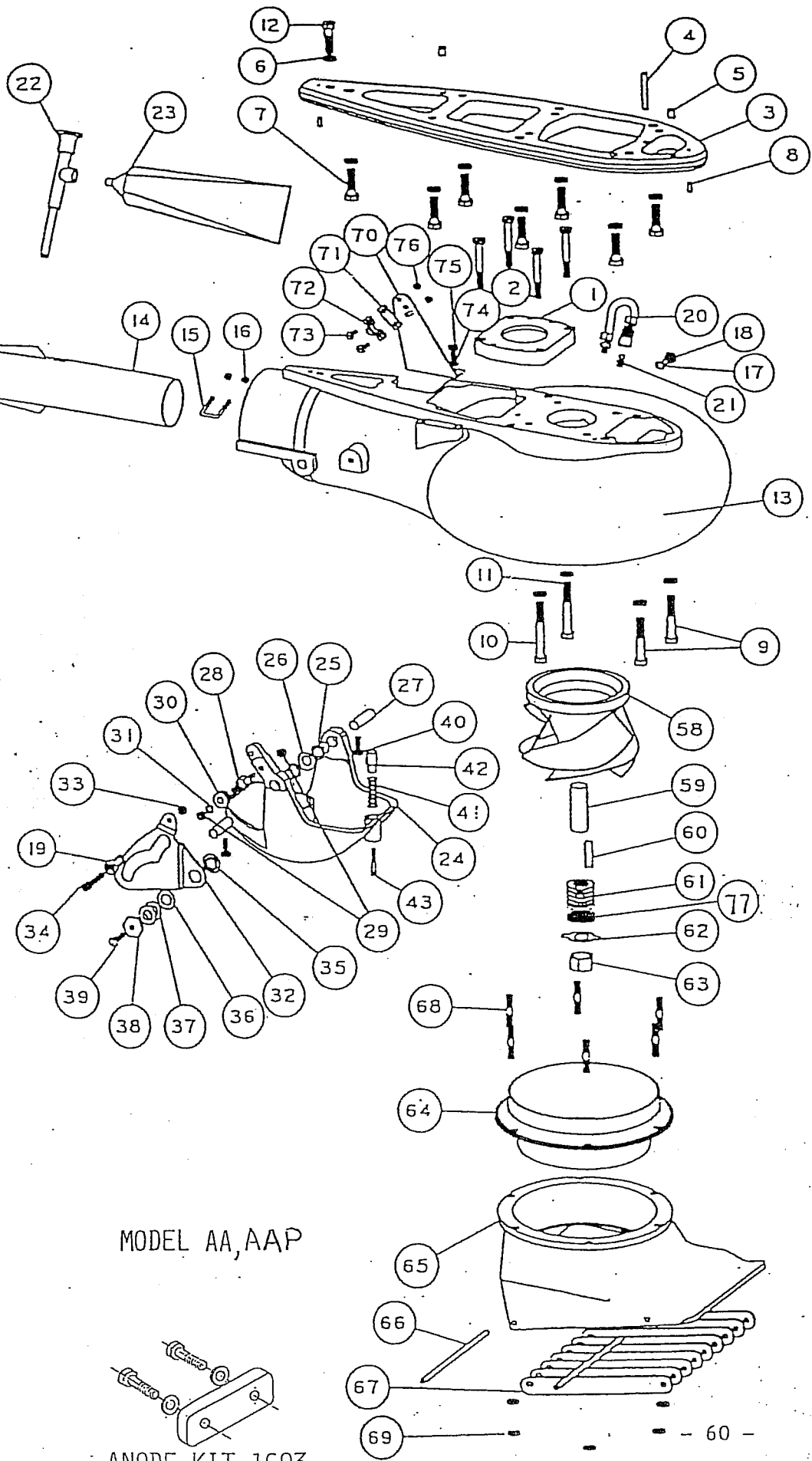

MODEL AA, AAP

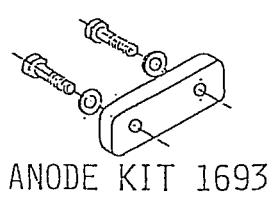

MODEL AA AND MODEL AAP (7 5/8 INTAKE) YAMAHA
AA4 V4 , AA6 V6 (2 STROKE), AA115-4 (IN-LINE 4 CYL. 4 STROKE)

REF	QTY	PART NO.	DESCRIPTION	REF	QTY	PART NO.	DESCRIPTION
1	1	938	PUMP ADAPTER AA	47	1	511	TRUARC 5100-98
2	4	603	BOLT HEX HD 5/16-18 X 2 1/2	48	1	404	BACKUP WASHER
3	1	936	ADAPTER PLATE AA	49	1	513	TRUARC N5002-250ZD
4	1	943	SHIFT ROD GUIDE AA-ROD	50	1	432	UPPER SEAL CARRIER W/SEALS & O RINGS
5	2	615	DOWEL PIN 8 X 12M	51	4	517	SPIROLOX RR-150S
6	12	636	WASHER SPRING LOCK M10	52	2	506	SEAL INNER
7	7	592	BOLT HEX HD M10-1.25 X 35MM	53	2	507	SEAL OUTER 6324-S
8	2	631	DOWEL PIN 3/16 X 1/2	54	2	527	O RING 568-141 3/32X2 5/16X2 1/2
9	2	608	BOLT HEX HD 3/8-16 X 2 1/4	55	1	393.5	BEARING CARRIER W/SEALS & O RINGS 5/16
10	1	609	BOLT HEX HD 3/8-16 X 2 3/4	56	3	521	O RING 568-011 1/16X5/16X7/16
11	1	610	BOLT HEX HD 3/8-16 X 3	57	4	602.1	BOLT HEX HD 5/16-18 X 1 PATCH
12	1	607	BOLT HEX HD 3/8-16 X 1 1/2	58	1	106.25	IMPELLER 7 3/8 V4, AA115-4 (4 STROKE)
		94100	VOLUTE WITH GATE AA	58	1	948	IMPELLER 7 3/8D V4, AA4 (2 STROKE)
13	1	941	VOLUTE WITH EXHAUST TUBE AA	58	1	1738	IMPELLER 4BLADE 7 3/8 V6 STAINLESS
14	1	128	EXHAUST TUBE ASSY LARGE 2 1/2	59	1	136	SHAFT SLEEVE PLASTIC LARGE
15	1	845	CLIP EXHAUST TUBE 1 3/8	60	1	434	IMPELLER TEE KEY - SQUARE
16	2	621	NYLOC 10-32	60	1	1706	IMPELLER TEE KEY - 1/2 ROUND
17	1	1025	WASHER FIBER M8	61	8	121	SHIM WASHERS
18	1	1024	BOLT HEX HD M8 1.25 X 12MM	62	1	781	NUTKEEPER (2 PER BAG)
19	1	553.2	BALL END 1/4X10-32 CABLE	63	1	122.1	SHAFT NUT 3/4-16 BRASS
20	1	975	LUBE HOSE ASSY			1333	INTAKE ASSY FLANGED WITH GRILL BAR & LINER
21	1	539	ZIRC FITTING 1/4-28	64	1	1431	LINER 7 3/8 FLANGED
22	1	550	GREASE GUN	65	1	1332	INTAKE PAINTED ONLY
23	1	552	GREASE 10 OZ TUBE NO. 630-AA	66	2	14	GRILL ROD
24	1	1172	REVERSE GATE LARGE	67	9	117	GRILL BAR LARGE
25	2	536	NYLINER 1/2 ID X 13/16	68	6	1319	STUD - INTAKE LARGE
26	1	1178	SPRING GATE PIVOT 1/2	69	6	625	NYLOC 5/16-18
27	2	823	PIN GATE PIVOT 1/2 LARGE			171	BRACKET ASSY MORSE W/CLAMP & HARDWARE
28	1	1043	SHAFT ROLLER	70	1	156	BRACKET CABLE SUPPORT
29	2	624	NYLOC 1/4-28	71	1	542	SHIM MORSE A035777
30	1	1042	ROLLER ASSY	72	1	543	CLAMP CHRYS 154317
31		635	1/4 WASHER AN960C416	73	2	561	FIL HD SLOTTED 10-24 X 5/8
32	1	1034	SHIFT CAM LARGE	74	8	640	WASHER SPRING LOCK 5/16
33	1	623	NYLOC 1/4-20	75	2	572	BOLT HEX HD 1/4-20 X 5/8
34	1	573	BOLT HEX HD 1/4-20 X 3/4	76	2	619	NYLOC 10-24
35	1	1037	BUSHING CAM	77	1	1719	TORSIONAL DAMPER 3/4
36	1	1038	WASHER CAM	78	4	640	WASHER SPRING LOCK 5/16
37	2	1039	SHIM - CAM				
38	1	1036	CAM ECCENTRIC DRILLED				
39	1	574.1	BOLT HEX HD 1/4-20 X 1 PATCH				MODEL AA6P - BALANCE OF PARTS SAME AS MODEL AA6
40	2	574	BOLT HEX HD 1/4-20 X 3/4 PATCH				
41	1	1170	SPRING GATE BUMPER	13	1	1699	VOLUTE WITH EXHAUST TUBE AAP
42	1	1497	GATE BUMPER			1700	VOLUTE WITH GATE AAP
43	1	559.2	FIL HD SLOTTED 10-32 X 1 1/4 PATCH	58	1	1721	IMPELLER 7 5/8 STAINLESS 200-225 HP
44	1	951	SHAFT ONLY, AA4,6 20T 30-11/16 LG	58	1	1735	IMPELLER 7 5/8 CB STAINLESS 150 HP
		952.1	SHAFT ASSY COMPLETE, AA4,6 20T-5/16	65	1	1602.01	INTAKE 7 5/8 PAINTED ONLY
44	1	1207	SHAFT ONLY, AAX, 20T 35-11/16 LG			1603.01	INTAKE ASSY 7 5/8 WITH GRILL & LINER
44		1208.1	SHAFT ASSY COMPLETE, AAX, 20T-5/16	64	1	1605	LINER 7 5/8 FLANGED
44	1	1655	SHAFT ONLY, AA115-4 18T 31 9/16 LG	66	2	1667	GRILL ROD
		1656.1	SHAFT ASSY COMPLETE, AA115-4 18T-5/16	67	10	1622	GRILL BAR X LARGE
45	1	41	SHAFT BEARING THRUST RING				
46	2	502	BEARING 7305B-UA				

SIZE	TORQUE
1/4-20 (M6)	8-9 FT-LBS
5/16-18 (M8)	12 FT-LBS
3/8-16 (M10)	22 FT-LBS

TILLER STEERING

SHIFT CABLE ASSY 1566, SEE PG. 26.1, THROUGH 2005
 2006 SHIFT CABLE ASSY 1857, SEE PG. 26.9

NEUTRAL CABLE ASSY, HPDI ONLY, 1566.3, SEE PG. 26.2

BEARING, SEAL, SNAP & "O" RING KIT, 2 BRG 462.2