

MODEL AJ-43 YAMAHA SERIES  
ASSEMBLY INSTRUCTIONS  
40 HP, 4 STROKE, 3 CYLINDER, 45.6 CU. IN., STARTING 1999

1. Place the engine on the transom of your boat so that it is mounted vertically, in the normal fashion. Remove the 5 bolts holding the gearbox to the exhaust housing and remove the gearbox assembly.
2. Remove the water pump assembly from the propeller drive, including the lower stainless steel plate and dowel pins.
3. Install the jet driveshaft assembly into the spiral pump housing locking it in place with the four 1/4-20 x 3/4 bolts and lockwashers. Use grease on the threads. Tighten to 8 ft-lbs.
4. Insert the clear plastic 1/2 long x 3/8 diameter sleeve in the 3/8 hole in the main housing, just ahead of the cooling water pump.

Install the water pump assembly on top of the stainless steel plate, using 4 – M8 x 30MM bolts and the special steel washers under the bolt heads. Be sure also, to install the water pump impeller drive key and dowel pins. Grease the threads. Before tightening the bolts, press the 3-7/8 long x 1/2 diameter plastic shift rod guide into the clear plastic sleeve, through the stainless steel plate until it bottoms. Tighten the bolts.

5. Remove the plastic water tube guide and rubber sleeve from the outlet of the cooling pump. Install the 5/8 diameter x 1/4 long plastic spacer in the outlet, followed by the rubber sleeve and the brass water tube extension. If there is a burr on the end of the motor cooling tube, file it smooth so the “O” ring inside the water tube extension will slide on.
6. The large 3/4 inch adapter plate is attached to the exhaust housing to hold the jet drive. Two 6 x 16MM dowels locate the plate, four M10 x 35MM bolts with lockwashers and one M8 x 30MM bolt with the lockwasher secure it. Grease the bolt threads.
7. Next, attach the jet drive to the motor. Use two 5/16-18 x 2-1/2 bolts (front), two 5/16-18 x 2-3/4 bolts (rear) from below with lockwashers, one 3/8-16 x 1-1/2 bolt and lockwasher, above rear, inside motor mid-section, and two 3/16 x 1/2 dowel pins.

Grease the bolt threads, driveshaft spline generously, and rubber water tube pilot and guide the jet into place. Tighten the 5 bolts.

8. Next, install the impeller. Grease the shaft threads, key and impeller bore. Place the plastic sleeve inside the impeller, hold the key in the nose of the impeller with your forefinger and slide onto the driveshaft. Install the 7 shim washers and nut retainer on the shaft, up against the impeller, and bring the nut up snug by hand. Be careful that the retainer does not fall into the thread groove and jam the nut.

Place the water intake in position and secure with 2 bolts. Observe the clearance between the impeller blade edge and the intake liner. Then remove the intake.

When, after use in sand and gravel, the blade clearance becomes more than about 1/32 inch between the impeller edge and the water intake liner, one or more of the stainless shim washers can be transferred from the bottom stack to the top of the impeller, which moves the impeller down into the tapered casing to reduce the clearance.

Shims should not be used above the impeller on new installations, where no wear has occurred, unless the blade clearance exceeds 1/32 inch. Insufficient blade clearance will do more harm than good from any performance gains it might provide.

When the impeller clearance is satisfactory, bump the nut up snug with a wrench. If the ears of the retainer do not line up with the flats on the nut, spin the nut off, turn the retainer over and tighten the nut again. In one of

MODEL AJ-43 YAMAHA SERIES  
ASSEMBLY INSTRUCTIONS  
40 HP, 4 STROKE, 3 CYLINDER, 45.6 CU. IN., STARTING 1999

these two positions you will have alignment and can fold the ears up against the nut to retain it. The flat in the retainer is angled to the ears to allow this.

9. Place the intake casing in position with the lower end at the rear and tighten the six 1/4-20 x 3/4 hex head bolts. No lockwashers are used. Grease the threads. See diagram page 3.
10. If your jet drive was ordered for use with a steering tiller handle, see attached page "Shift Cable and Handle Assembly Instructions," pages 4-5.
11. If your motor is equipped for remote controls, proceed as follows:

Attach the shift cable and cable anchor bracket to the jet drive.

With the shift handle in forward and the reverse gate in forward, with the cam roller at the end of the slot, adjust the cable end and/or cable anchor position to this condition. Shift to reverse and back to forward. The roller should be at the end of the cam slot such that the gate cannot be forcibly rotated toward reverse. Pull on the gate by hand to verify this.

If this forward lock condition is not met, readjust the cable positions.

12. When converting to jet drive, your motor will have to be raised to height shown in diagram on page 3, using a straight edge under the boat. Test run the boat and then raise or lower the motor 5/16 inch at a time to obtain the best results.

The motor has four sets of upper mounting holes. You will use one set to begin with. Mark pencil lines on the boat transom through the other sets. Then if you wish to go up or down 5/16 inch, you can drill one alternate set of holes 5/16 inch up or down from the pencil marks. By alternating between these two sets of transom holes and the four sets of motor holes, the motor can be moved in 5/15 inch increments over almost one inch. The transom height should be about 21 inches measured vertically from the boat bottom for short shaft motors and 26 inches for long shaft.

If you raise it too much it will suck air and cavitate, either on start up or when banking on turns. When cavitating, the motor overspeeds in spurts and shakes considerably in the motor mount. This is not a normal condition and should be avoided by proper adjustment of motor height on each individual boat. If you lower it too much you will have excessive drag, therefore mount the motor as high as possible without allowing cavitation.

### CAUTION

When starting the engine for the first time, watch to see that cooling water comes out of the small hole at the rear side of engine just below the powerhead. This is to check your assembly of the cooling water pump and its connections.

### SETTING MOTOR HEIGHT

MODEL AJ-43 YAMAHA SERIES  
ASSEMBLY INSTRUCTIONS  
40 HP, 4 STROKE, 3 CYLINDER, 45.6 CU. IN., STARTING 1999

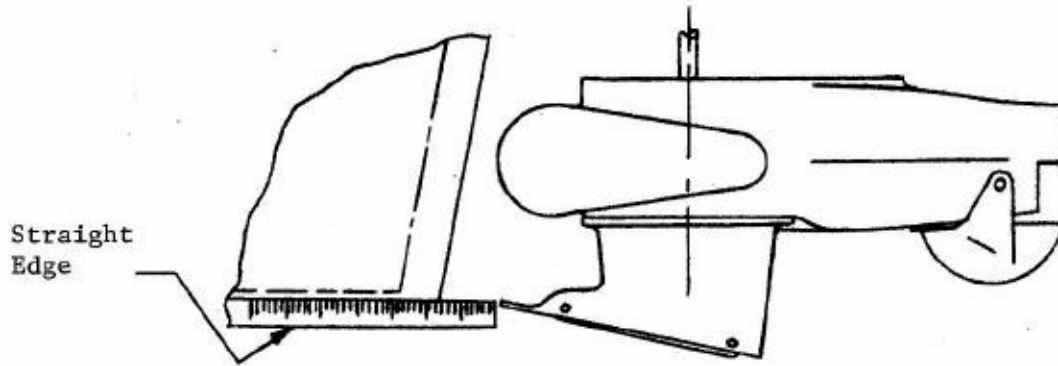

**CAUTION**

When starting the engine for the first time, watch to see that the cooling water comes out of the small hole at the rear side of the engine just below the power head. This is to check your assembly of the cooling water pump and its connections.

**MAINTENANCE AND LUBRICATION**

See last page.

# MAINTENANCE AND LUBRICATION OUTBOARD JET DRIVE

## **BEARING LUBRICATION**

A grease gun and tube of grease is supplied with your jet drive. We recommend greasing the bearing every 10 hours. Make greasing a part of your cleanup after the days use. Pump in just enough grease to fill the lube hose. Then reconnect the lube hose coupling to the zerk grease fitting.

Every 30-40 hours, pump in extra grease so as to purge any moisture. The texture of the grease coming out gives an indication of conditions inside the bearing housing. A gradual increase in moisture content indicates seal wear. If the grease begins to turn dark, dirty gray, the bearing and seals should be inspected and replaced if necessary. Some discoloration of the grease is normal during the break in period on new sets of seals.

We have selected a water resistant grease of the proper consistency for this application. If you use a substitute grease, be sure it is water resistant and of the same consistency.

## **IMPELLER**

Your jet drive is equipped with a key to protect the unit in the event of a rock jam. This can be reached by removing the water intake, and then the driveshaft nut, similar to a propeller drive. After replacing the key, pull the shaft nut up tight to remove any play between the impeller and shaft. Note the position of the impeller shim washers, and replace them in the same order.

## **REVERSE GATE MECHANISM**

Occasionally check adjustment of the gate shifting linkage. In "forward" the gate should be firmly locked in position. Pull on the gate by hand to verify this. This will prevent wave action from accidentally shifting the gate into reverse as the boat is violently maneuvered

## **GENERAL**

Check all mounting bolts, intake screws, linkage connections, etc., occasionally to be sure they are tight.

## **SALT WATER USE**

Aluminum and stainless steel have been used in the construction of your jet drive. These materials have either been treated or are inherently resistant to corrosion. It is recommended, however, that when not in use the motor be tipped up so that the jet unit is out of the water. When used in salt water more than in fresh water, remove mounting hardware, grease, and reassemble once a year. Failure to do this may result in hardware that is difficult if not impossible to remove at a later date.

## **GUARANTEE**

Due to inflexible government regulation, we do not have a written warranty. We have, however, a good reputation for fairness with our customers which we intend to maintain. If you think you have a warranty situation, regarding material, workmanship, call us before making repairs.

Specialty Manufacturing Company  
Outboard Jets  
2035 Edison Avenue  
San Leandro, CA 94577

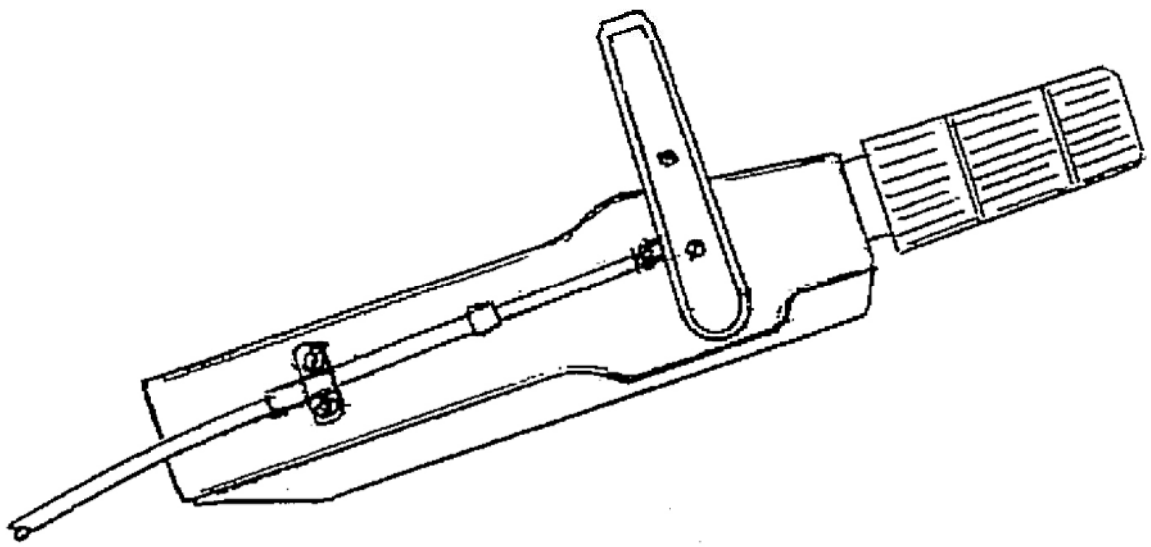

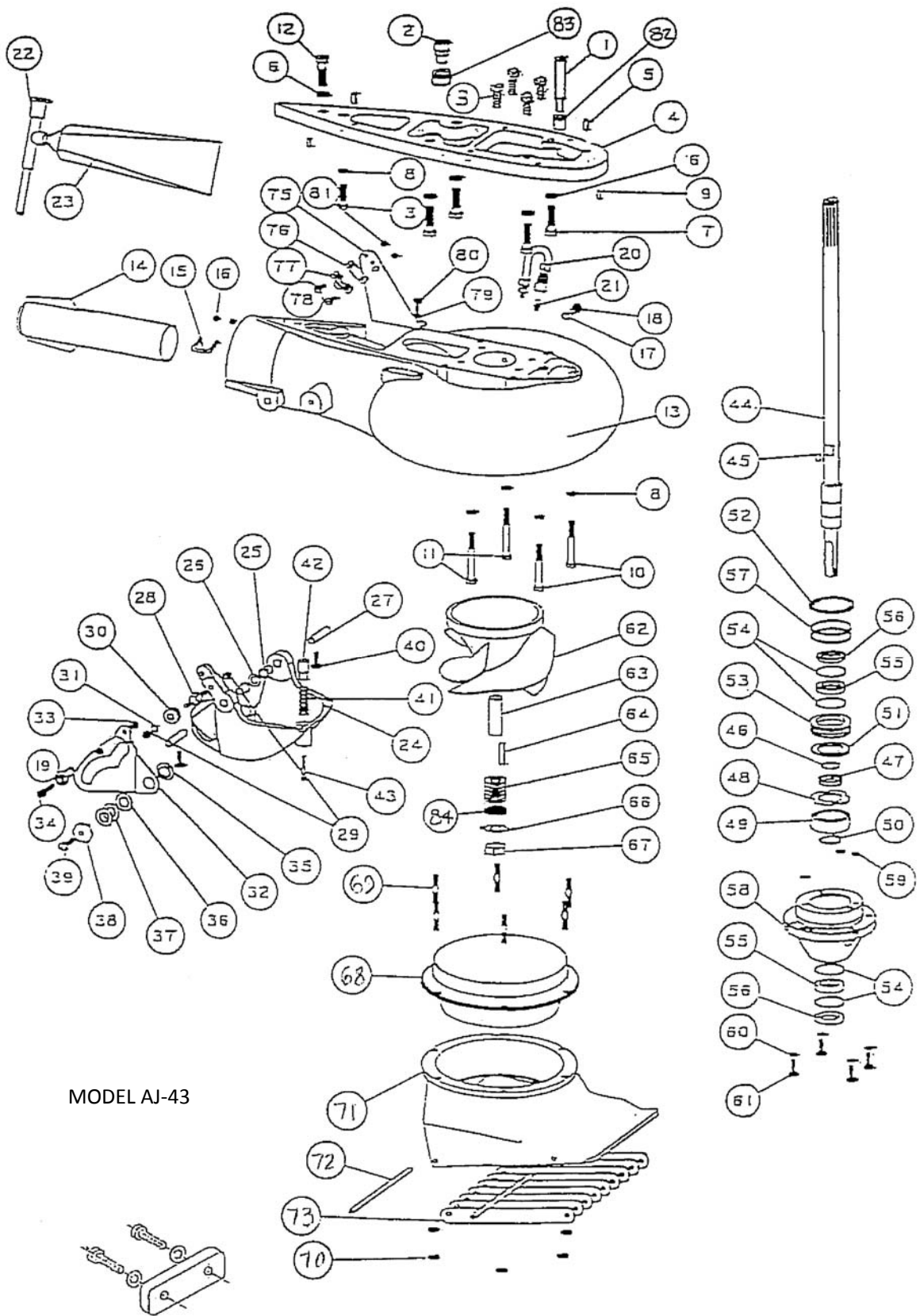

MODEL AJ-43

ANODE KIT 1693

## MODEL AJ-43 YAMAHA 4 STROKE 3 CYL 40HP

REF	QTY	PART NO.	DESCRIPTION	REF	QTY	PART NO.	DESCRIPTION
1	1	1651	SHIFT ROD GUIDE AJ-43	46	1	41	SHAFT BEARING THRUST RING
2	1	1377	WATER TUBE EXTENSION - AJ	47	1	477	COLLAR BACKFIT 7205
3	5	591	BOLT HEX HD M8-1.25 X 30MM	48	1	832	THRUST WASHER
4	1	1366	ADAPTER PLATE AJ	49	1	504	BEARING 7205B-UA
5	2	616	DOWEL PIN 6 X 16 MM	50	1	511	TRUARC 5100-98
6	5	636	WASHER SPRING LOCK M10	51	1	833	SPACER
7	4	592	BOLT HEX HD M10-1.25 X 35MM	52	1	512	TRUARC N5002-212ZD
8	5	640	WASHER SPRING LOCK 5/16	53	1	433	UPPER SEAL CARRIER W/ SEALS & O RINGS
9	2	631	DOWEL PIN 3/16 X 1/2	54	4	517	SPIROLOX RR-150S
10	2	603	BOLT HEX HD 5/16-18 X 2 1/2	55	2	506	SEAL INNER
11	2	599	BOLT HEX HD 5/16-18 X 2 3/4	56	2	507	SEAL OUTER 6324-S
12	1	607	BOLT HEX HD 3/8-16 X 1 1/2	57	2	526	O RING 568-135 3/32X1 15/16X2 1/8
		1370	VOLUTE WITH GATE AJ	58	1	1380	BEARING CARRIER W/SEALS & O RINGS AJ
13	1	1369	VOLUTE WITH EXHAUST TUBE AJ	59	3	521	O RING 568-011 1/16X5/16X7/16
14	1	80	EXHAUST TUBE ASSY MEDIUM 2	60	4	638	WASHER SPRING LOCK 1/4
15	1	846	CLIP EXHAUST TUBE 1	61	4	573	BOLT HEX HD 1/4-20 X 3/4
16	2	621	NYLOC 10-32	62	1	8.23	IMPELLER 6 1/8 W/36 SLEEVE
17	1	1023	WASHER FIBER 3/8	62	1	1737	IMPELLER 6 1/8 W/36 SLEEVE, STAINLESS
18	1	1022	BOLT HEX HD 3/8-16 X 1/2	63	1	36	SHAFT SLEEVE PLASTIC MEDIUM
19	1	553.2	BALL END 1/4X10-32 CABLE	64	1	782	IMPELLER TEE KEY - SQUARE
20	1	975	LUBE HOSE ASSY	64	1	1705	IMPELLER TEE KEY - 1/2 ROUND
21	1	539	ZIRC FITTING 1/4-28	65	8	21	SHIM WASHER MEDIUM
22	1	550	GREASE GUN	66	1	805	NUTKEEPER MED/PKG 2 PER BAG
23	1	552	GREASE 10 OZ TUBE 630-AA	67	1	22.1	SHAFT NUT 5/8-18 BRASS
24	1	1175	REVERSE GATE, MEDIUM			31.2	INTAKE ASSY 6 1/8 WITH GRILL & LINER
25	2	535	NYLINER 3/8 1D X 11/16	68	1	93.22	LINER 6 1/8 W/HARDWARE
26	1	1177	SPRING GATE PIVOT 3/8	69	2	638	WASHER SPRING LOCK 1/4
27	2	822	PIN GATE PIVOT 3/8 MEDIUM	70	2	572	BOLT HEX HD 1/4-20 X 5/8
28	1	1043	SHAFT ROLLER	71	1	7	INTAKE PAINTED ONLY
29	2	624	NYLOC 1/4-28	72	2	14	GRILL ROD
30	1	1042	ROLLER ASSY	73	9	16	GRILL BAR MEDIUM
31	1	635	1/4 WASHER AN960C416	74	6	573	BOLT HEX HD 1/4-20 X 3/4
32	1	1035	SHIFT CAM MEDIUM			171	BRACKET ASSY MORSE W/CLAMP & HARDWARE
33	1	623	NYLOC 1/4-20	75	1	156	BRACKET CABLE SUPPORT
34	1	573	BOLT HEX HD 1/4-20 X 3/4	76	1	542	SHIM MORSE A035777
35	1	1037	BUSHING CAM	77	1	543	CLAMP CHRYS 154317
36	1	1038	WASHER CAM	78	2	561	FL HD SLOTTED 10-24 X 5/8
37	2	1039	SHIM-CAM	79	2	635	1/4 WASHER AN960C416
38	1	1036	CAM ECCENTRIC DRILLED	80	2	572	BOLT HEX HD 1/4-20 X 5/8
39	1	574.1	BOLT HEX HD 1/4-20 X 1 PATCH	81	2	619	NYLOC 10-24
40	2	574	BOLT HEX HD 1/4-20 X 3/4 PATCH	82	1	1650	CUSHION-SHIFT ROD GUIDE
41	1	1170	SPRING GATE BUMPER	83	1	1649	SPACER-WATER TUBE
42	1	1169	GATE BUMPER	84	1	1718	TORSIONAL DAMPER 5/8
43	1	559.2	FIL HD SLOTTED 10-32 X 1 1/4 PATCH				
44	1	1643	SHAFT ONLY, AJS-43, 14T 24 9/16 LG				
		1644	SHAFT ASSY COMPLETE, AJS-43, 14T W/1275 KEY				
44	1	1647	SHAFT ONLY, AJL-43, 14T 29 9/16 LG	NOTE: FLUSH SCREW & WASHER METRIC			
		1648	SHAFT ASSY COMPLETE, AJL-43, 14T W/1275 KEY	17	1	1025	WASHER FIBER M8
45	1	1275	KEY, TEE WATER PUMP	18	1	1024	BOLT HEX HD M8-1.25 X 12

SIZE	TORQUE
1/4-20 (M6)	8-9 FT-LBS
5/16-18 (M8)	12 FT-LBS
3/8-16 (M10)	22 FT-LBS

TILLER STEERING – SEE PAGE 34.2

SHIFT CABLE ASSY 1566.1 SHORT

SHIFT CABLE ASSY 1566.2 LONG

BEARING, SEAL, SNAP & “O” RING KIT 803.1

MEDIUM SERIES  
 SHIFT CABLE ASSEMBLY  
 SHIFT HANDLE ON  
 STARBOARD SIDE OF TILER STEERING HANDLE  
 AJS-43 1566.1  
 AJS-43 1566.2

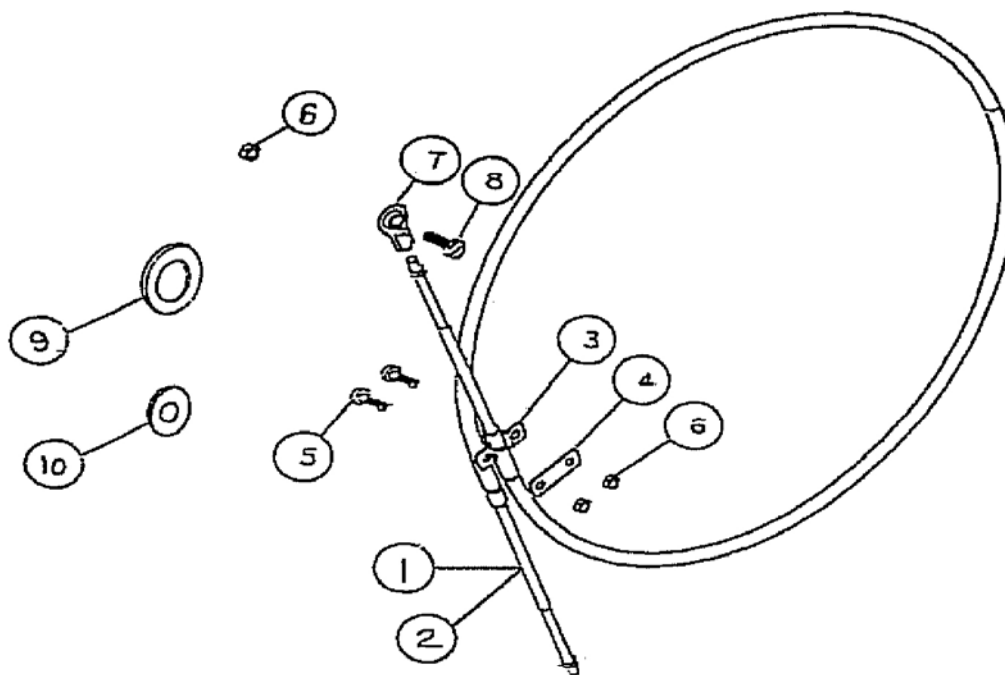

REF	QTY	PART NO.	DESCRIPTION
1	1	547.1	CABLE 4 1/2 FT MOR 33C SUPREME SHORT
2	1	547.2	CABLE 5 FT MOR 33C SUPREME LONG
3	1	543	CLAMP CHRYS 154317
4	1	542	SHIM MORSE 1035777
5	2	558	FIL HD SLOTTED 10-32 X 1 1/4
6	3	621	NYLOC 10-32
7	1	553.1	BALL END #10 X 10-32 CABLE
8	1	1567	SCREW HEX HD 10-32 X 3/4 MOD
9	1	1568	SHIM WASHER LARGE
10	1	1569	SHIM WASHER SMALL



MODEL AJ-43 TILLER HANDLE STEERING  
SHIFT CABLE ASSEMBLY 1566.1, 1566.2

1. Remove the plastic covers from the shift handle and the steering arm. Remove the shift handle.
2. Cut out the template for the shift handle and the cable anchor position on the steering arm.
3. Fold the cable anchor pattern along the dotted lines and place it on the steering arm with the fork up inside, straddling the threaded boss. Tape in position.
4. Place the shift handle pattern over the handle boss. Tape in position, center punch the 3 hole locations and drill through using 3/16 drill. The holes in the steering arm are long, reaching through the threaded boss itself.
5. Attach the ball rod end to the shift handle and tighten the thin head hex screw and lock nut. Remove the flanged plastic bushing, place the 1/16 thick spacer washer on the handle and replace the flanged bushing. Place the smaller 1/16 thick spacer over the square driver and install the handle.
6. Thread the shift cable all the way into the shift handle rod end. Attach the cable body to the steering arm using the shim, U-clamp, 2 #10-32 x 1-1/4 screws and lock nuts.

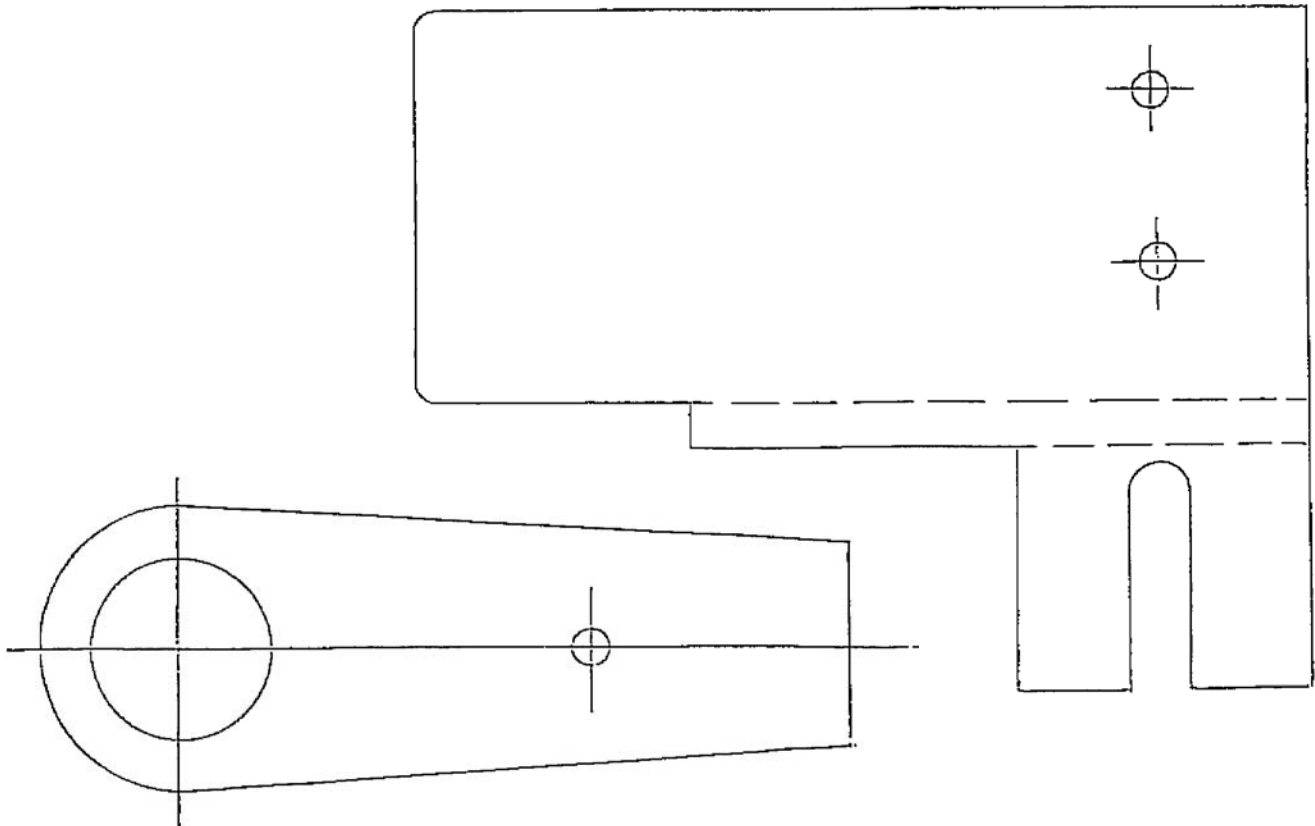

MODEL AJ-43 TILLER HANDLE STEERING  
SHIFT CABLE ASSEMBLY 1566.1, 1566.2

7. Attach the lower end of the cable to the jet drive with the ball rod end threaded on the cable as far as it will go and the cable anchor bracket slid forward and locked. Twist the cable in the U-clamp so that the cable rests against the motor cowling and tighten the clamp screws.

8. Place the shift handle in forward, solidly in the detent. The reverse gate cam roller must be at the end of the slot in the cam. If these conditions are not met, slide the cable anchor bracket on the jet drive and/or adjust the threaded rod end on the cable.

9. Shift to reverse and back to forward. Do not be concerned if the gate does not reach reverse. There is clearance at this position and water pressure will close the gate.

10. In forward, with the roller at the end of the cam slot, the gate cannot be forcibly rotated toward reverse. Pull on the gate by hand to verify this.

11. Lock the nuts on the cable against the rod ends to complete the adjustment and install the plastic covers.

**CAUTION** You must return the throttle to idle before shifting.

TILLER SHIFT CABLE ASSY  
YAMAHA STARTING 2006  
1856 SHORT  
1857 LONG

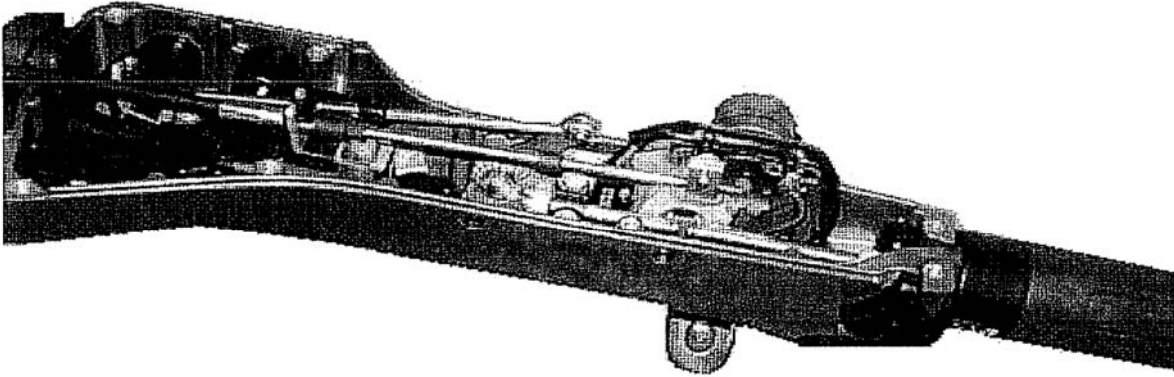

1. Remove the lower plastic cover from the steering handle.
2. Remove the shift cable.
3. Install the 4 ½ ft. or 5 ft. standard 33C cable, using the cable end 1851.
4. Attach the lower end of the cable to the jet drive with the ball rod end threaded on the cable as far as it will go and the cable anchor bracket centered and locked. Twist the cable in the U-clamp so that the cable rests against the motor cowling and tighten the clamp screws. The clamp base is slotted to allow alignment for minimum cable bending.
5. Place the shift handle in forward, solidly in the detent. The reverse gate cam roller must be at the end of the slot in the cam. If these conditions are not met, slide the cable anchor bracket on the jet drive and/or adjust the threaded rod end on the cable.
6. Shift to reverse and back to forward. Do not be concerned if the gate does not reach reverse. There is clearance at this position and water pressure will close the gate.
7. In forward, with the roller at the end of the cam slot, the gate cannot be forcibly rotated toward reverse. Pull on the gate by hand to verify this.
8. Lock the nuts on the cable against the rod ends to complete the adjustment and reassemble the lower cover of the steering arm.

CAUTION You must return the throttle to idle before shifting.

TILLER SHIFT CABLE ASSY  
YAMAHA STARTING 2006  
1856 SHORT  
1857 LONG

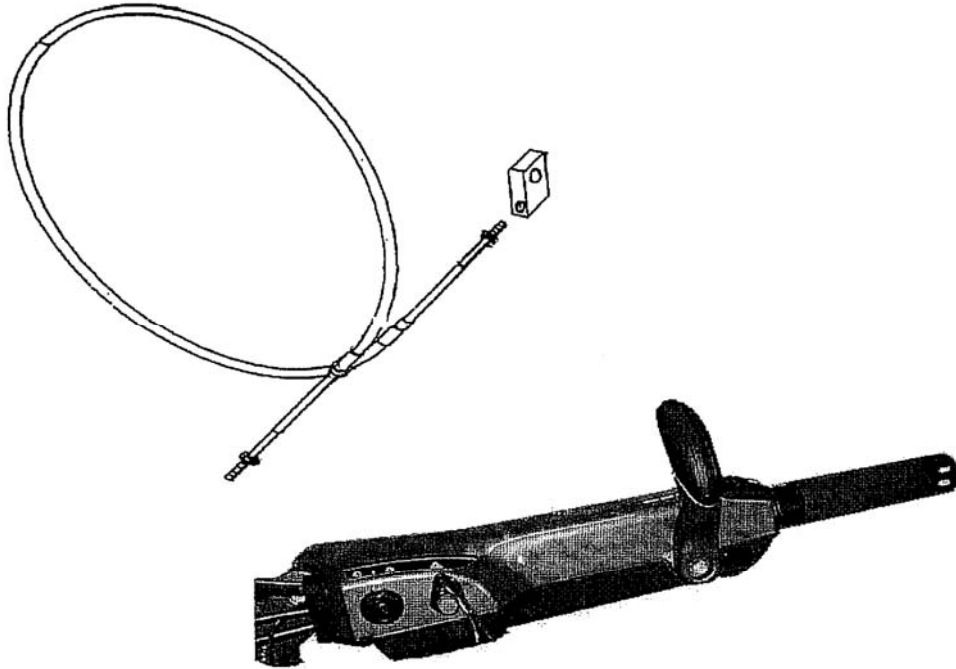

REF	QTY	PART NO.	DESCRIPTION
1	1	547.1	CABLE 4 1/2 FT MOR 33C SUPREME LONG
1	1	547.2	CABLE 5 FT MOR 33C SUPREME LONG
2	1	1851	CABLE END YAMAHA 2006 TILLER

NEUTRAL CABLE ASSEMBLY  
 AA6P, HPDI, AQ, AJSM06-43  
 1566.3

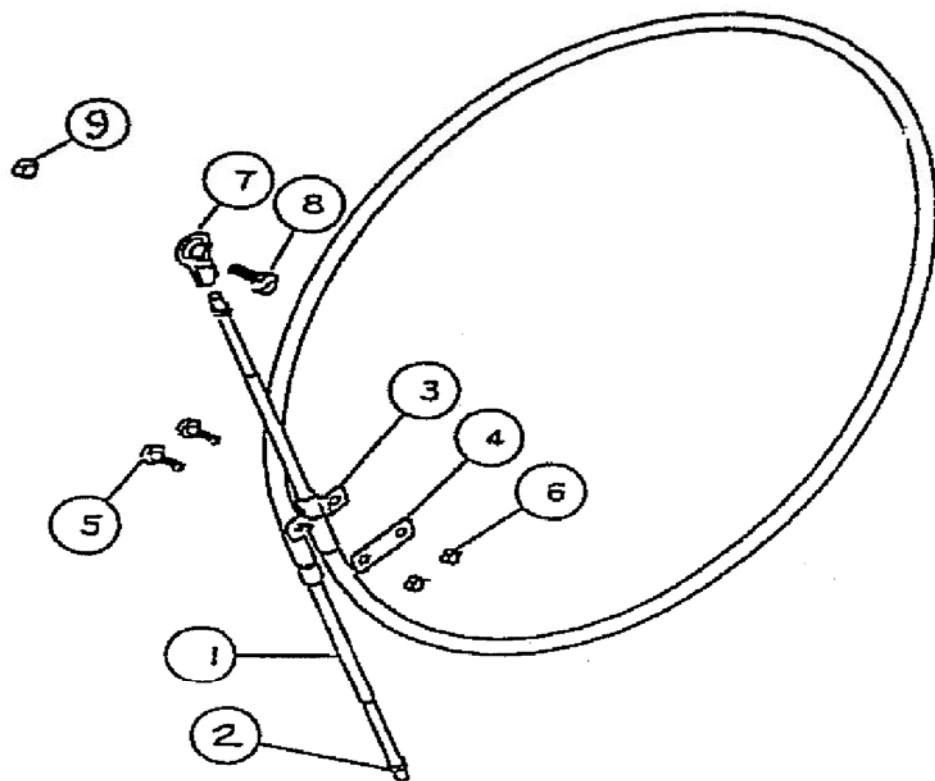

REF	QTY	PART NO.	DESCRIPTION
1	1	547.2	CABLE 5 FT MOR 33C SUPREME
2	2	621.1	HEX NUT 10-32 JAM
3	1	543	CLAMP CHRYS 154317
4	1	542	SHIM MORSE AO35777
5	2	561.1	SCREW #10-24 X 3/4
6	2	619	NYLOC #10-24
7	1	553.2	BALL END 1/4X10-32 CABLE
8	1	585	BOLT HEX HD 1/4-20 X 1 1/4
9	1	623	NYLOC 1/4-20