

MODEL BP SERIES  
ASSEMBLY INSTRUCTIONS  
150HP MERCURY 4 CYL., 4 STROKE 183 CU. IN.

1. Place the engine on the transom of your boat so that it is mounted vertically, in the normal fashion. Remove the bolts holding the gearbox to the exhaust housing and remove the gearbox assembly.
2. Remove the water pump assembly from the propeller drive, including the lower stainless steel plate, dowel pins, and impeller drive key.
3. Install the jet driveshaft assembly into the spiral pump housing locking it in place with the four 5/16-18 x 1 bolts with lock washers. Use grease on the threads. Tighten to 15 Ft-Lbs.
4. Install the water pump assembly on top of the stainless steel plate. Be sure also, to install the water pump impeller drive key removed from the propeller drive. No gasket is needed beneath the lower stainless steel plate. Use the four metric bolts and centering washers from the propeller gearbox. Grease the threads. Install the brass water tube extension on the water pump outlet.
5. The large 3/4" adapter plate is attached to the exhaust housing to hold the jet drive. Install the 5/16 x 2 1/2 plastic shift rod guide into the adapter plate. Two 8 x 12MM dowels locate the plate. Use the Mercury gearbox hardware, 4 fiber lock nuts, washers, 1 rear bolt and washer. Grease the threads and tighten to 30 Ft-Lbs.
6. The shift cable anchor bracket must be moved out to clear the exhaust housing splash fin. Attach the 1/8 x 1 1/2 x 2 3/4 stainless plate to the jet drive using two 1/4-20 x 5/8 bolts and flat washers. Grease the threads.

Next, attach the jet drive to the motor. Two 3/16 x 1/2 dowel pins center the jet drive on the adapter plate. Four 3/8-16 bolts from below and the Mercury trim tab bolt from above rear with lockwashers are used. Select the lower bolt lengths to suit the different counter bore depths so that all bolts enter the adapter plate the same depth. The upper rear bolt is reached through the trim tab opening in the motor exhaust housing.

Grease the bolt threads, driveshaft spline generously, and rubber water tube pilot and guide the jet into place. Tighten to 22 Ft-Lbs.

7. Next, install the impeller. Grease the shaft threads, key and impeller bore. Place the plastic sleeve inside the impeller, hold the key in the nose of the impeller with your forefinger and slide onto the driveshaft. Install the eight shim washers and nut retainer on the shaft, up against the impeller, and bring the nut up snug by hand. **Be careful that the retainer and shim washers do not fall into the thread groove and jam the nut.**

Then bump the nut up snug with a wrench. If the ears of the retainer do not line up with the flats on the nut, spin the nut off, turn the retainer over and tighten the nut again. In one of these two positions you will have alignment and can fold the ears up against the nut to retain it. The flat in the retainer is angled to the ears to allow this.

When, after use in sand and gravel, the blade clearance becomes more than about 1/32" between the impeller edge and the water intake liner, one or more of the shim washers can be transferred from the bottom stack to the top of the impeller, which moves the impeller down into the tapered casing to reduce the clearance.

MODEL BP SERIES  
ASSEMBLY INSTRUCTIONS  
150HP MERCURY 4 CYL., 4 STROKE 183 CU. IN.

**Shims should not be used above the impeller on new installations where no wear has occurred unless the blade clearance exceeds 1/32 inch. Insufficient blade clearance will do more harm than good from any performance gains it might provide.**

8. Place the intake casing in position with the lower end at the rear and tighten the six nuts. No lock washers are used. Grease the threads.
9. Attach the shift cable and cable anchor bracket to the jet drive.
10. With the shift handle in forward and the reverse gate in forward, **with the cam roller at the end of the slot, adjust the cable and/or cable anchor position to this condition. Shift to reverse and back to forward. The roller should be at the end of the cam slot such that the gate cannot be forcibly rotated toward reverse. Pull on the gate by hand to verify this.**

If this forward lock condition is not met, readjust the cable positions.

11. **When converting to jet drive, your motor will have to be raised to height shown in diagram below, using a straight edge under the boat.** Test run the boat and then raise or lower the motor 5/16 inch at a time to obtain the best results.

The motor has three sets of upper mounting holes. You will use one set to begin with. Mark pencil lines on the boat transom through the other sets. Then if you wish to go up or down 5/16 inch, you can drill one alternate set of holes 5/16 inch up or down from the pencil marks. By alternating between these two sets of transom holes and the three sets of motor holes, the motor can be moved in 5/16 inch increments over almost one inch. The transom height should be about 26" measured vertically from the boat bottom.

**If you raise it too much it will suck air and cavitate, either on start up or when banking on turns.** When cavitating, the motor over speeds in spurts and shakes considerably in the motor mount. **This is not a normal condition and should be avoided by proper adjustment of motor height on each individual boat.** If you lower it too much you will have excessive drag, therefore mount the motor as high as possible without allowing cavitation

### **SETTING MOTOR HEIGHT**

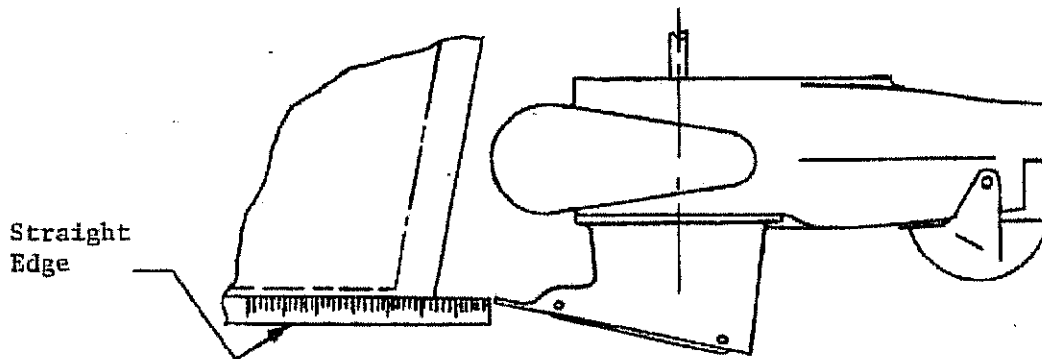

### **CAUTION**

MODEL BP SERIES  
ASSEMBLY INSTRUCTIONS  
150HP MERCURY 4 CYL., 4 STROKE 183 CU. IN.

**When starting the engine for the first time, watch to see that the cooling water comes out of the small hole at the rear side of the engine just below the power head.** This is to check your assembly of the cooling water pump and its connections.

**MAINTENANCE AND LUBRICATION**

See last page.

**CAUTION**

**V4 and V6 jet drives**

It is important on high HP installations to mount the motor at the correct height and to use the power tilt properly.

Power tilt is convenient for drifting and when operating at low throttle in very shallow areas. When under power however, the engine should not be tilted out in an effort to gain speed as is done with propellers.

The engine driveshaft should be vertical when planing or tilted toward the boat in order to provide a scooping angle on the water intake grill. **Tilting the motor out beyond a vertical position reduces the scoop angle and can cause impeller slippage and cavitation burns on the impeller blades.**

When running in a bay, lake or wide river in windy conditions, particularly when running with the wind, the jet can suck in air when jumping across the wave crests. This will result in over speeding and causes severe strain on the driveshaft when the engine is suddenly brought back to normal speed as the impeller once again grabs solid water.

If your boat is used frequently under these conditions, the engine height should be set lower than normal to minimize over speeding. Running at reduced throttle will help when winds are strong. You can also experiment with a plate extending from the hull bottom to the top of the leading edge of the water intake as shown in paragraph 7 of the owners' manual. This tends to reduce air intake as well as to reduce spray.

**A water intake fin kit, part #1726 is now available.** The purpose of these fins is to ram more water into the intake and to shield the forward sides of the intake from the entrance of air. There is a noticeable reduction of engine over speeding when running with the wind on a heavy chop. To a lesser degree, the fins provide some rudder effect when operating at a low speeds. This is not a cure all for cavitation and it is still necessary to set the engine height and angle properly and to minimize obstructions or imperfections in the hull ahead of the intake.

GOOD BOATING AND HAVE FUN!

Specialty Manufacturing Company  
Outboard Jets  
2035 Edison Avenue  
San Leandro, CA 94577

# **MAINTENANCE AND LUBRICATION OUTBOARD JET DRIVE**

## **BEARING LUBRICATION**

A grease gun and tube of grease is supplied with your jet drive. We recommend greasing the bearing every 10 hours. Make greasing a part of your cleanup after the days use. Pump in just enough grease to fill the lube hose. Then reconnect the lube hose coupling to the zerk grease fitting.

Every 30-40 hours, pump in extra grease so as to purge any moisture. The texture of the grease coming out gives an indication of conditions inside the bearing housing. A gradual increase in moisture content indicates seal wear. If the grease begins to turn dark, dirty gray, the bearing and seals should be inspected and replaced if necessary. Some discoloration of the grease is normal during the break in period on new sets of seals.

We have selected a water resistant grease of the proper consistency for this application. If you use a substitute grease, be sure it is water resistant and of the same consistency.

## **IMPELLER**

Your jet drive is equipped with a key to protect the unit in the event of a rock jam. This can be reached by removing the water intake, and then the driveshaft nut, similar to a propeller drive. After replacing the key, pull the shaft nut up tight to remove any play between the impeller and shaft. Note the position of the impeller shim washers, and replace them in the same order.

## **REVERSE GATE MECHANISM**

Occasionally check adjustment of the gate shifting linkage. In "forward" the gate should be firmly locked in position. Pull on the gate by hand to verify this. This will prevent wave action from accidentally shifting the gate into reverse as the boat is violently maneuvered

## **GENERAL**

Check all mounting bolts, intake screws, linkage connections, etc., occasionally to be sure they are tight.

## **SALT WATER USE**

Aluminum and stainless steel have been used in the construction of your jet drive. These materials have either been treated or are inherently resistant to corrosion. It is recommended, however, that when not in use the motor be tipped up so that the jet unit is out of the water. When used in salt water more than in fresh water, remove mounting hardware, grease, and reassemble once a year. Failure to do this may result in hardware that is difficult if not impossible to remove at a later date.

## **GUARANTEE**

Due to inflexible government regulation, we do not have a written warranty. We have, however, a good reputation for fairness with our customers which we intend to maintain. If you think you have a warranty situation, regarding material, workmanship, call us before making repairs.

Specialty Manufacturing Company  
Outboard Jets  
2035 Edison Avenue  
San Leandro, CA 94577

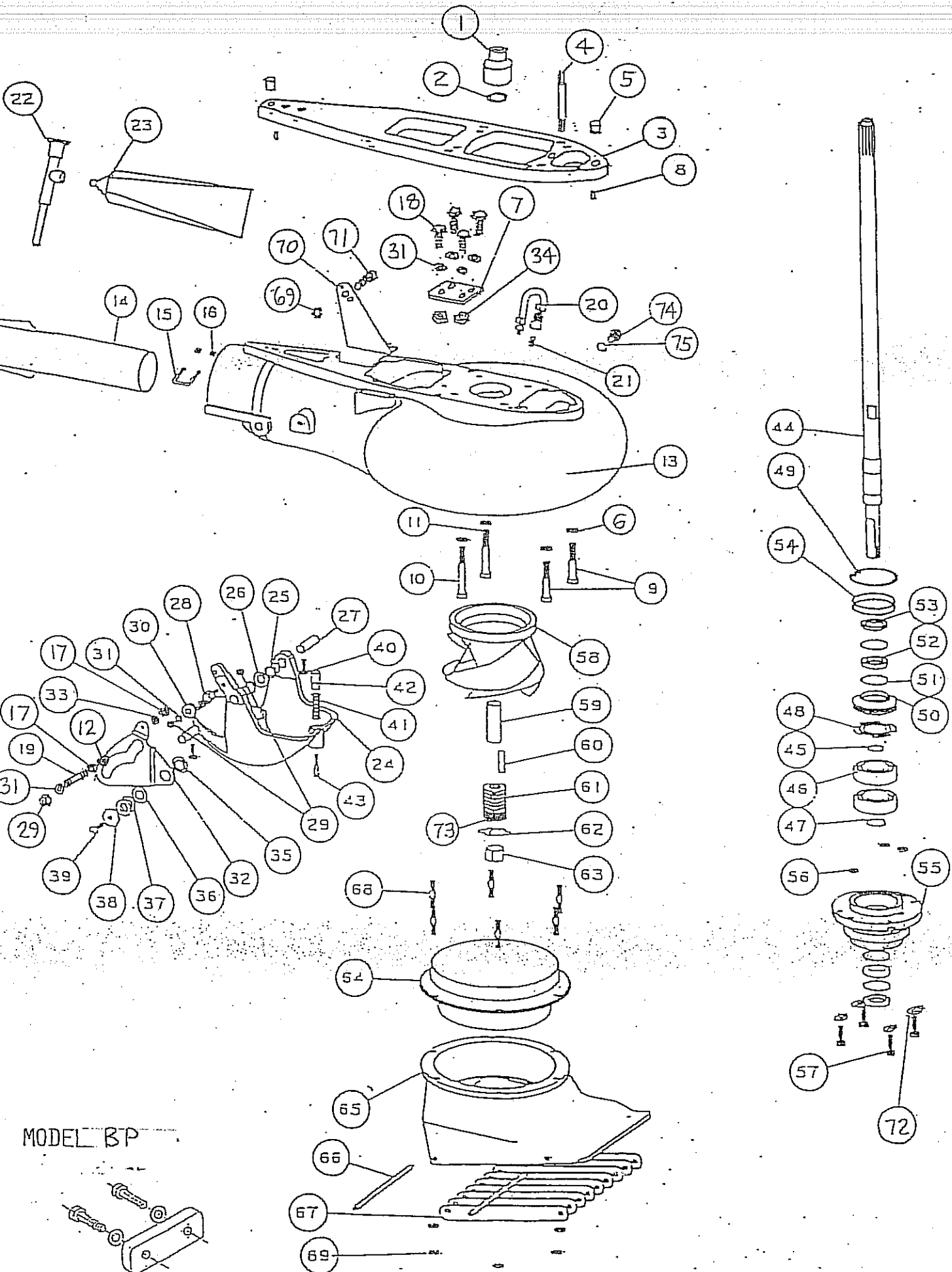

MODEL BP

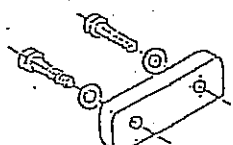

ANODE KIT 1693

**MODEL BP MERCURY  
150HP  
4 CYL. 4 STROKE 183 CU. IN.**

REF	QTY	PART NO.	DESCRIPTION	REF	QTY	PART NO.	DESCRIPTION
1	1	1634	WATER TUBE EXT AR W/O-RING	49	1	513	TRUARC N5002-250ZD
2	1	525.1	O-RING 1/8 X 13/16 X 1 1/16 - 211	50	1	432	UPPER SEAL CARRIER W/SEALS & O RINGS
3	1	2146	ADAPTER PLATE BP	51	4	517	SPIROLOX RR-150S
4	1	2157	SHIFT ROD GUIDE BP	52	2	506	SEAL INNER
5	2	615	DOWEL PIN 8 X 12M	53	2	507	SEAL OUTER 6324-S
6	4	636	WASHER SPRING LOCK M10	54	2	527	O RING 568-141 3/32X2 5/16X2 1/2
7	1	1666	OFFSET PLATE	55	1	393.5	BEARING CARRIER W/SEALS & O RINGS 5/16
8	2	631	DOWEL PIN 3/16 X 1/2	56	3	521	O RING 568-011 1/16X5/16X7/16
9	2	608	BOLT HEX HD 3/8-16 X 2 1/4	57	4	602.1	BOLT HEX HD 5/16-18 X 1 PATCH
10	1	609	BOLT HEX HD 3/8-16 X 2 3/4	58	1	1721	IMPELLER 7 5/8 W/136 SLEEVE STAINLESS
11	1	610	BOLT HEX HD 3/8-16 X 3	59	1	136	SHAFT SLEEVE PLASTIC LARGE
12	1	790	SPACER	60	1	434	IMPELLER TEE KEY - SQUARE
		1626	VOLUTE WITH GATE AR / BP	60	1	1706	IMPELLER TEE KEY - 1/2 ROUND
13	1	1625	VOLUTE WITH EXHAUST TUBE AR / BP	61	8	121	SHIM WASHERS
14	1	128	EXHAUST TUBE ASSY LARGE 2 1/2	62	1	781	NUT KEEPER LARGE 2 PER BAG
15	1	845	CLIP EXHAUST TUBE 1 3/8	63	1	122.1	SHAFT NUT 3/4-16 BRASS
16	2	621	NYLOC 10-32			1603.04	INTAKE ASSY FLANGED WITH GRILL BAR & LINER
17	2	622	NUT 1/4-28	64	1	1605	LINER 7 5/8 FLANGED
18	4	572	BOLT HEX HD 1/4-20 X 5/8	65	1	1602.04	INTAKE PAINTED ONLY
19	1	1199	PIVOT CABLE END	66	2	1667	GRILL ROD
20	1	975	LUBE HOSE ASSY	67	10	1622	GRILL BAR X LARGE
21	1	539	ZIRC FITTING 1/4-28	68	6	1319	STUD - INTAKE LARGE
22	1	550	GREASE GUN	69	7	625	NYLOC 5/16-18
23	1	552	GREASE 10 OZ TUBE NO. 630-AA			334	BRACKET ASSY MERCURY W/HARDWARE
24	1	1172	REVERSE GATE LARGE	70	1	153	BRACKET CABLE SUPPORT MERCURY
25	2	536	NYLINER 1/2 ID X 13/16	71	1	597	BOLT HEX HD 5/16-18 X 1 1/4
26	1	1178	SPRING GATE PIVOT 1/2	72	4	640	WASHER SPRING LOCK 5/16
27	2	823	PIN GATE PIVOT 1/2 LARGE	73	1	1719	TORSIONAL DAMPER 3/4
28	1	1043	SHAFT ROLLER	74	1	1022	BOLT HEX HD 3/8-16 X 1/2
29	2	624	NYLOC 1/4-28	75	1	1023	WASHER FIBER 3/8
30	1	1042	ROLLER ASSY				
31	6	635	1/4 WASHER AN960C416				
32	1	1034	SHIFT CAM LARGE				
33	1	638	WASHER SPRING LOCK 1/4				
34	2	623	NYLOC 1/4-20				
35	1	1037	BUSHING CAM				
36	1	1038	WASHER CAM				
37	2	1039	SHIM - CAM				
38	1	1036	CAM ECCENTRIC DRILLED				
39	1	574.1	BOLT HEX HD 1/4-20 X 1 PATCH				
40	2	574	BOLT HEX HD 1/4-20 X 3/4 PATCH				
41	1	1170	SPRING GATE BUMPER				
42	1	1497	GATE BUMPER				
43	1	559.2	FIL HD SLOTTED 10-32 X 1 1/4 PATCH				
44	1	2152	SHAFT ONLY, BP 20T 30 3/16 LG				
		2153.1	SHAFT ASSY COMPLETE, BP, 20T 5/16				
44	1	2155	SHAFT ONLY, BPX 20T 35 3/16 LG				
		2156.1	SHAFT ASSY COMPLETE, BPX 20T 5/16				
45	1	41	SHAFT BEARING THRUST RING				
46	2	502	BEARING 7305B-UA				
47	1	511	TRUARC 5100-98				
48	1	404	BACKUP WASHER				

SIZE	TORQUE
1/4-20 (M6)	8-9 FT-LBS
5/16-18 (M8)	12 FT-LBS
3/8-16 (M10)	22 FT-LBS

BEARING, SEAL, SNAP & "O" RING KIT 462.2