

Adjustable Transom Bracket

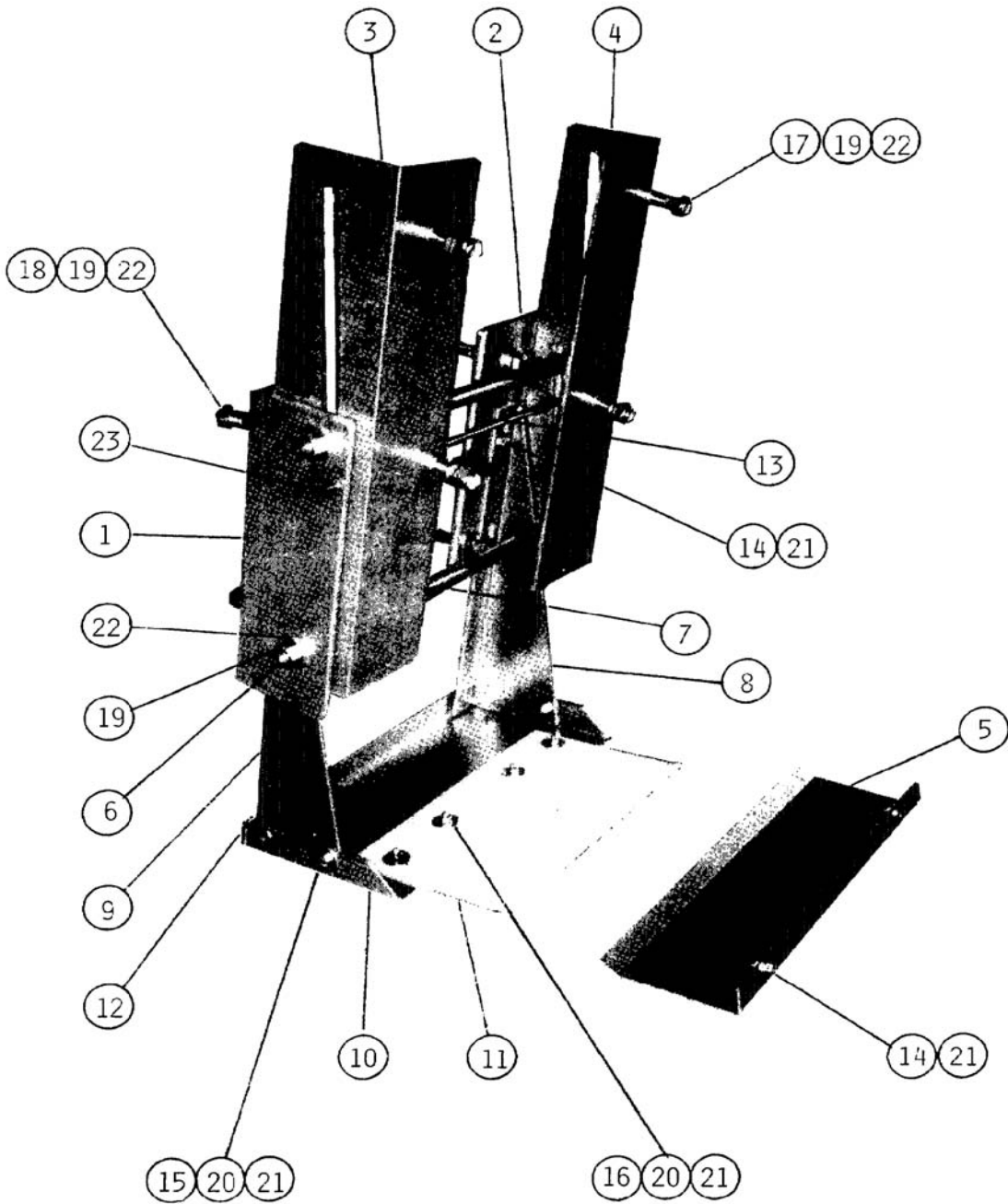

ADJUSTABLE TRANSOM BRACKET INSTALLATION INSTRUCTION

1. Mount the bracket on the boat using 4-1/2-13 X 3-1/2 “ bolts, lock nuts and washers under both the bolt head and nut, with the nuts inside the boat. Grease the threads.

The bracket must sit flat against the transom to prevent binding in the slides. Washers can be placed between the bracket and the transom to clear rivet or screw heads or clearance can be drilled or rotary filed in the bracket face.

2. Lower the motor slide all the way down and mount the motor, selecting the set of holes in the motor bracket that positions the anti-cavitation plate on the propeller drive at the correct height relative to the boat bottom. Use 4-1/2-13 X 2-1/2” bolts, lock nuts, and washers under both the bolt head and nut, with the nuts regularly facing the rear. Grease the threads.

3. Tilt the motor out, install the jet drive and tilt the motor back to a vertical position relative to the boat bottom.

4. Using a jack under the heel of the jet drive water intake, or a hoist, raise the motor until the bottom of the leading edge of the water intake is flush with the bottom of the boat. If there is binding in the slide, loosen the motor bolts slightly to free it up. When in position, lock the motor bolts and the 4 nuts on the 2 tie rods to lock the slide.

5. Once again, tilt the motor out. Mount the left and right hand splash plate supports to the transom bracket using 4-1/4-20 X 1/2” bolts and 1/4 X 1 washers. Grease the threads.

6. Attach the splash plate with plastic flap to the support brackets using 4-1/4-20 X 3/4” bolts with 1/4 X 1 washers under the bolt heads and nuts. Grease the threads.

7. Adjust the splash plate and supports until the bottom of the plate is flush with the bottom of the boat, the sponge is compressed against the boat transom and the plastic flap is resting on the top of the leading edge of water intake. Tighten the 8 bolts. If your boat has a vee bottom (up to 10 degrees), the aluminum splash plate can be formed with 3 bend lines and a vee cut in the forward flange to provide a transition from a vee at the forward edge to a flat rear edge to support the plastic flap.

8. The rear edge of the plastic flap is bent upward so that when the motor is tilted out and back in again the leading edge of the intake will find its way back under the flap without stubbing the edge. When the motor is steered from left to right, the flap will flex as it rides up on the raised section of the intake. Adjust the fore and aft position of the flap, if necessary, and tighten the 4 nuts.

9. Take the boat out for a test run. If the boat tends to porpoise (the bow romping up and down), the motor can be lowered slightly, tilting the rear of the splash plate down with it. This can provide a trim tab effect to level the boat. For the test run, take along 2

approximately 8" C-clamps. Tighten 1 on each motor slide about ¼" above the top edge of the transom brackets. Loosen the tie rod nuts to lower the slide ¼" if necessary. Tighten the nuts, reset the splash plate, and test again. When the height is satisfactory, it can be left at this setting regardless of the load being carried in the boat.

10. A ¼ x 17 ½" rod is provided to set this finalized upper slide position, and act as a safety against slide movement downward. Center a 17/64 drill at the lower end of the ¾" slots in the left and right hand transom brackets, just below the upper tie rod. Drill horizontally through the adjacent motor mount plates. Slide the rod through and secure with the rubber caps.

11. To switch from jet drive to propeller drive, tilt the motor out and remove only the 4 bolts holding the vertical support members of the splash plate assembly to the transom mount. Store as an assembly to leave the lower plate adjustments intact. Install the propeller drive splash plate at the bottom of the motor mount slides, using 2-1/4-20 X ½" bolts and ¼ X 1" washers. Grease the threads.

12. Remove the jet drive, install the propeller drive and return the motor to the vertical position. Remove the ¼" upper position rod and store it with the splash bracket. **Carefully** loosen the tie rod nuts just enough to allow the motor mount to slide to the lower position. If the slide sticks, retighten the tie rod nuts and loosen the motor mount bolts to relieve binding. Then, **carefully** loosen the tie rod nuts and lower the slide. Pulling rearward on the prop drive lower unit will also relieve binding. **Be careful, you may wish to use a hoist or jack to lower the motor as was done to raise it.**

13. If the need arises to make a long run in deep water using the propeller drive to conserve fuel in order to reach a shallow river where the jet drive is required, a change in motor height can be made in the field if the motor is equipped with power trim. Carry, in the boat, a piece of ¾" plywood about 1 square foot. Tilt the motor out about 20 degrees and back the boat up to a shallow beach. Loosen the transom bracket tie rod nuts, rest the propeller skeg on the plywood pad and power trim the motor down to a vertical position. The floating boat will be drawn backwards, raising the motor slide. It may be necessary to repeat this step to reach the desired height. If you tilt the motor out too far in an effort to make the entire lift in one step, the hydraulics may not be able to overcome the leverage.

Specialty Manufacturing Company
Outboard Jets
2035 Edison Avenue
San Leandro, CA 94577
Tele. (510)562-6049

TRANSOM BRACKET 1570

REF	QTY	PART NO.	DESCRIPTION
1	1	1525	TRANSOM BRACKET-LEFT HAND
2	1	1526	TRANSOM BRACKET-RIGHT HAND
3	1	1527	MOTOR BRACKET-LEFT HAND
4	1	1528	MOTOR BRACKET-RIGHT HAND
5	1	1529	SPLASH PLATE-PROPELLER
6	2	1530	TIE ROD
7	2	1531	SPACER TUBE
8	1	1555	SPLASH BRACKET-RIGHT HAND
9	1	1556	SPLASH BRACKET-LEFT HAND
10	1	1557	SPLASH PLATE
11	1	1558	SPLASH FLAP
12	1	1565	ADHESIVE FOAM STRIP
13	1	1533	UPPER POSITION ROD 1/4"
14	6	571	HEX HD BOLT 1/4-20 X 1/2
15	4	573	HEX HD BOLT 1/4-20 X 3/4
16	4	587.2	FLAT HD PHILLIPS SCREW 1/4-20 X 3/4
17	4	614.2	HEX HD BOLT 1/2-13 X 2-1/2
18	4	614.3	HEX HD BOLT 1/2-13 X 3-1/2
19	12	626.1	NYLOC NUT 1/2-13
20	8	623	NYLOC NUT 1/4-20
21	18	633	FLAT WASHER 1/4 X 1 X .060 THK
22	32	633.1	FLAT WASHER 1/2 X 1-1/4 X .105 THK
23	2	1571	RUBBER CAP - 1/4" ROD